

Ultra-small single-turn absolute rotary encode

SROA13-17Bit-SYD-W0.5-5V

SROA20-17Bit-SYD-W0.5-5V

SPECIFICATION

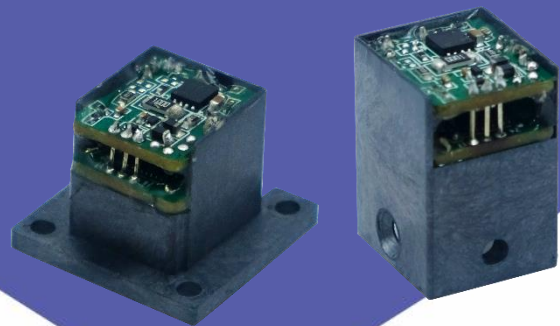

Contents

1. Summary Info.....	2
2. Technical Specifications.....	3
3. Electrical Parameters.....	4
4. Cable Definition.....	4
5. Mechanical Specifications.....	4
5.1 SROA13 Series.....	4
5.2 SROA20 Series.....	5
6. 安装方式.....	6
6.1 SROA13 Series.....	6
6.2 SROA20 系列.....	7
7. 通讯协议.....	8
7.1 概述.....	8
7.2 E ² PROM 通信规格.....	8
7.3 帧格式.....	8
7.4 详述.....	9
8. 时序说明.....	12
8.1 时序图.....	12
8.2 详细指标.....	12

1. Summary Info

This manual primarily describes how to use the Ultra-small single-turn absolute rotary series SROA13 and SROA20 encoder from Reagle Sensing. This product is mainly used in servo-driven control systems, providing the feedback information required for accurate position and speed control units.

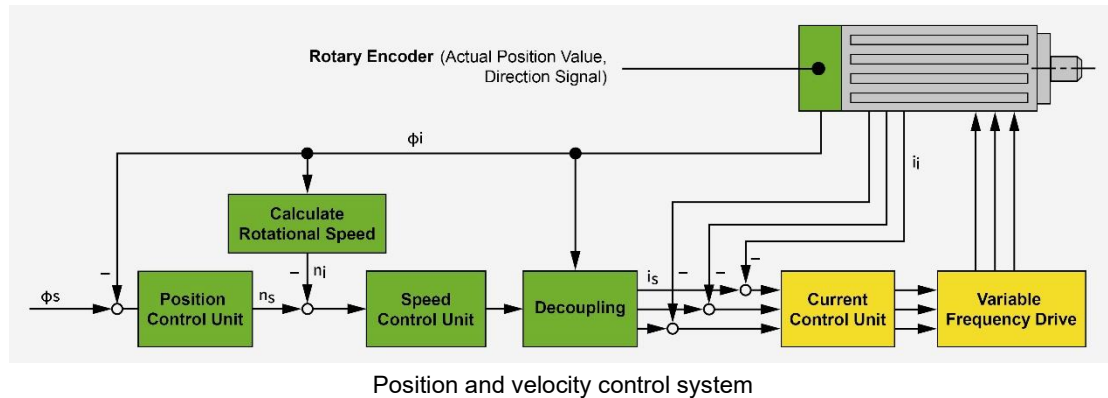

The performance of the encoder has a decisive impact on the essential characteristics of the motor, such as:

- Positioning accuracy
- Speed stability
- Bandwidth, determining the response speed to drive command signals and resistance to interference
- Motor size
- Noise

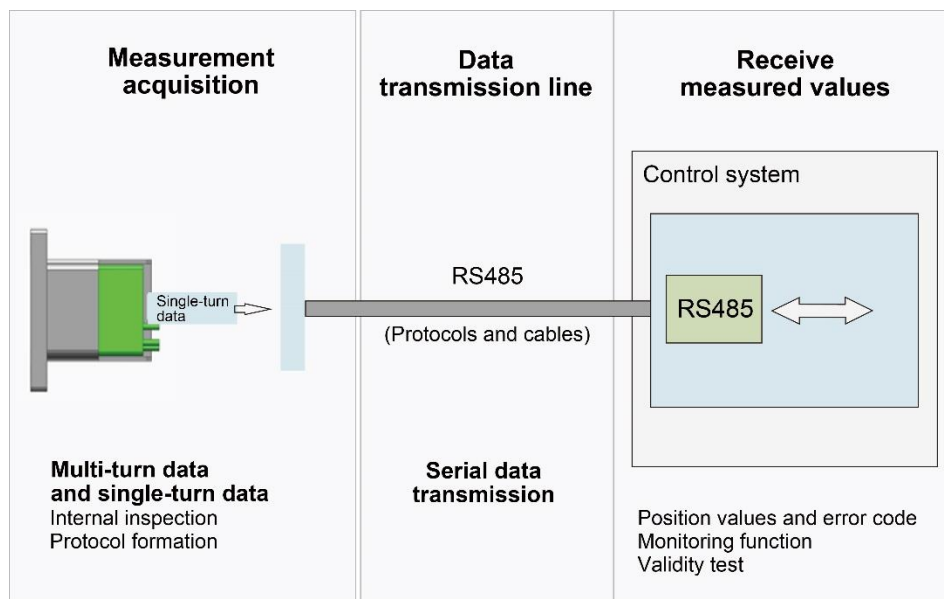

RS485 Communication Encoder

2. Technical Specifications

Model	SROA13-17Bit-SYD-W0.5-5V SROA20-17Bit-SYD-W0.5-5V
Resolution	Supports up to 131072 (17bit)
Auxiliary Functions	Fault Warning * Electromagnetic Environment Warning
Communication Interface	RS485
Communication frequency	≤16kHz
Baud rate	2.5Mbps
Input shaft allowable deviation	Axial: ±0.1mm Axial play: <0.1mm Radial: ±0.1mm Radial play: <0.01mm Tilt: <0.1°
Main shaft speed	≤5000rpm
shaft diameter	straight shaft Ø4mm
moment of inertia	0.003kg·mm ²
weight	≈0.003kg (without cables)
rotational angular acceleration	≤80000rad/s ²
Vibration	Between 10 and 55Hz, maintain amplitude of 1.5mm. Between 55 and 2000Hz, acceleration is 98m/s ² . 2 hours per axis for XYZ, totaling 6 hours.
Mechanical shock	Shock acceleration of 980m/s ² , 11 milliseconds. 3 impacts per direction, totaling 18 impacts.
Operating Temperature	-10°C~105°C
Relative Humidity	≤90% (40°C/21 days, based on EN 60068-2-78); No condensation
Enclosure Protection Rating	— (Motor Rear Case Protection) Avoid dust, moisture, oil, and other contaminants during operation and use.

3. Electrical Parameters

Items	T=25°C		
	Min.	Typ.	Max.
Main power supply voltage	4.75 V	5V	5.25V
Main power supply Current (Typ)	--	140mA	--
Differential Level	High	--	--
	Low	--	1.7V
Edge Change Time	--	--	100ns
Insulation resistance	50MΩ	--	--

4. Cable Definition

Cable color	Definition
Red	5V
Black	GND
Blue	485+
Yellow	485-

5. Structural Dimensions

5.1 SROA13 Series

◇ Product Structure Dimension Diagram

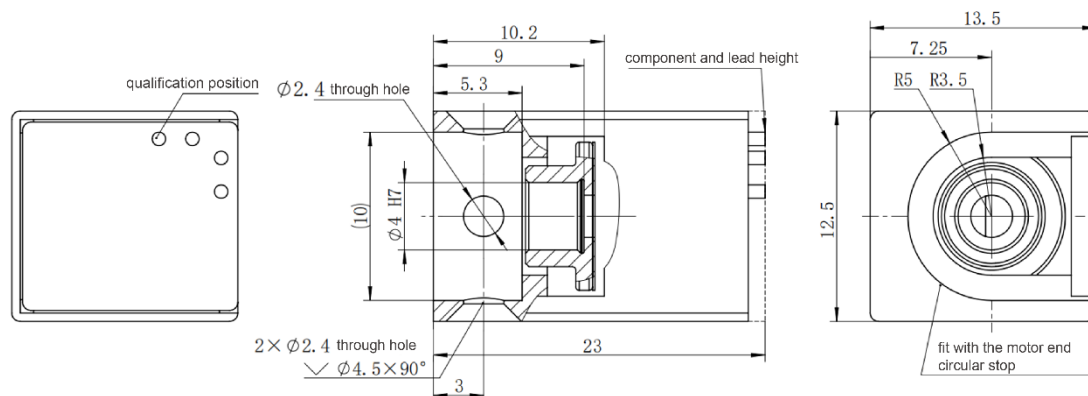

【Note】 6.0mm Lead-out with a flexible wire, length 0.5m, outer diameter 6.0mm.

◇ Recommended Motor End Design Dimensions

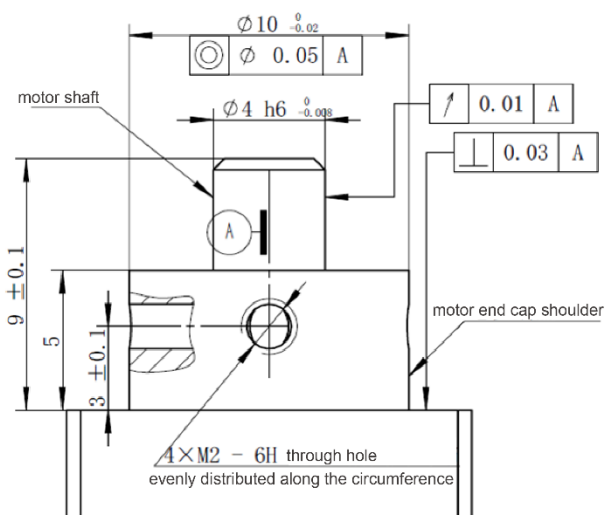

5.2 SROA20 Series

◇ Product Structure Dimension Diagram

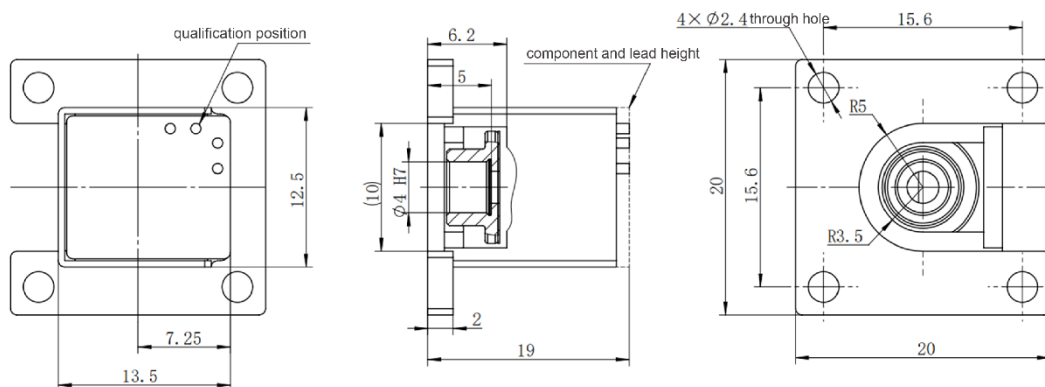

【Note】 6.0mm Lead-out with a flexible wire, length 0.5m, outer diameter 6.0mm.

◇ Recommended Motor End Design Dimensions

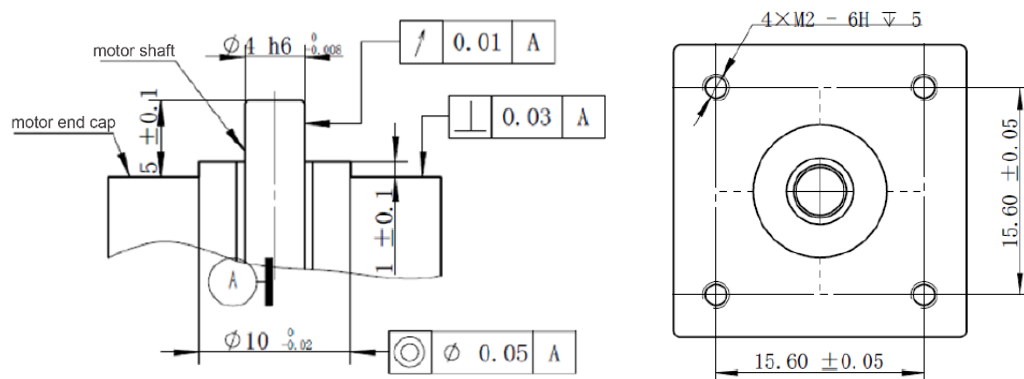

6. Mounting Procedure

6.1 SROA13 Series

6.1.1 Installation Accessories

- Cross Head Torque Screwdriver

6.1.2 Installation Sequence

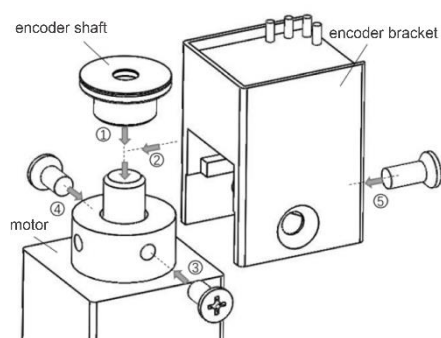

- ① Assemble the encoder shaft onto the motor shaft using structural adhesive (recommend using anaerobic adhesives like Loctite 638/648). Ensure that the end face of the motor shaft is flush with the end face of the encoder's inner hole, and make sure no adhesive overflows onto the code disk surface;
- ② Slide the encoder bracket assembly radially over the encoder shaft (note: during the insertion process, ensure that the bracket notch aligns with the code disk height to avoid collision and friction). After the bracket contacts the motor end cover stop, place it downward so that the inner circular stop of the bracket aligns with the motor end cover stop;
- ③ Tighten one side screw using a cross-bit torque screwdriver;
- ④ Tighten the other side screw using a cross-bit torque screwdriver;
- ⑤ Tighten the third screw using a cross-bit torque screwdriver (this can be done simultaneously with the motor rear cover);
- ⑥ Complete the encoder installation and perform installation testing using the specialized Eagle Sensor workstation.

【Note】 :

1. It is recommended that users protect the motor rear cover to prevent contamination of the code disk and electronic components. The screw at position ⑤ can be installed after coordinating with the motor rear cover;
2. To prevent loosening of the above screws, you can either apply thread locker to the threaded holes in advance or use screws with pre-applied thread locker. It is recommended to use a tightening torque of 2.0 ± 0.2 kgf·cm for the screws;
3. The screws at positions ③ and ④ should be countersunk screws, and the screw at position ⑤ must be equipped with a flat washer

6.2 SROA20 Series

6.2.1 Installation Accessories

- Cross Head Torque Screwdriver

6.2.2 Installation Sequence

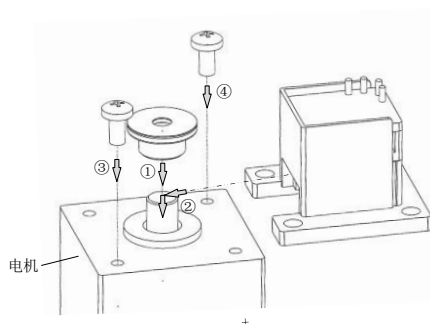

- ① Assemble the encoder shaft into the motor shaft and secure it using structural adhesive (recommended to use anaerobic adhesive such as Loctite 638/648). During assembly, ensure that the end face of the motor shaft is flush with the end face of the encoder inner bore, and make sure there is no adhesive overflow contaminating the code disk surface;
- ② Pass the main body of the encoder bracket radially over the encoder shaft (note: during the insertion process, ensure that the bracket's notch aligns with the height of the code disk to avoid contact and friction with the code disk). Once the bracket touches the motor end cover stop, place it downward so that the inner stop of the bracket aligns with the stop on the motor end cover;
- ③ Use a crosshead screwdriver to tighten a screw on one side;
- ④ Use a crosshead screwdriver to tighten the screw on the other side;
- ⑤ Complete the encoder installation and use the SharpEagle sensor-specific workstation for installation verification;

【Note】 :

1. It is recommended to protect the motor's rear cover to prevent contamination of the code disk and electronic components.
2. The screws mentioned in notes ③ and ④ must have flat washers. To prevent loosening, apply thread-locking adhesive to the threaded holes beforehand or use screws pre-coated with thread-locking adhesive. Recommended screw tightening torque is 2.0 ± 0.2 kgf·cm.

【Precautions】 :

1. This encoder has a split design, with the encoder shaft (including the code disk) separate from the main structure. The encoder shaft and motor shaft need to be exposed to air during installation, so please assemble in a clean, dust-free environment.
2. Before installation, clean and degrease the motor shaft to avoid affecting the encoder shaft's fastening or contaminating the code disk.

3. During installation, avoid contaminating the code disk surface, as fingerprints, oil, and dust can cause signal abnormalities.
4. If contamination occurs after installation, gently wipe with a lint-free cloth moistened with alcohol. Avoid excessive force or using hard materials, as this could damage the code disk.
5. Do not apply excessive tension to the encoder cable to prevent deformation of the encoder or damage to the cable, which could affect the encoder's signal output.

7. Communication Specifications

7.1 Overview

Items	Description	Remarks
Communication Code System	Binary	--
Communication Circuit	Differential Drive	RS485
Data Transmission Content	Single-Turn Position Information	17 bit
Communication Rate	2.5 Mbps	--

7.2 E²PROM Communication Specifications

Items	Address	Description	Remarks
Readable and Writable User Parameter Address Range	0~0x7E* page8	User Parameter Domain	This address domain can be used to store user parameters. The partial area on page 8 is reserved and not recommended for customer use.
Page Address	0x7F	0~7	Within this range
Maximum Number of Erase Cycles	100000 次		Executable Operation Count

7.3 Frame Format

Each data frame is divided into several data words. Each data word is transmitted and received with 1 start bit, 8 data bits, and 1 stop bit, with the least significant bit first and the most significant bit last.

In the data frame transmission, the following terms are used:

Items	Description	Remarks
CF	Control Field	Identifies different command types.
SF	Status Field	Provides information on the encoder's status
DF	Data Field	Encoder Position Data
ADF	Address Field	Accessible Encoder Address
EDF	E2PROM Field	The content at the specified address
CRC	CRC 校验	Polynomial: x8+1 (XOR all data except CRC)

7.3.1 Position Data Reading

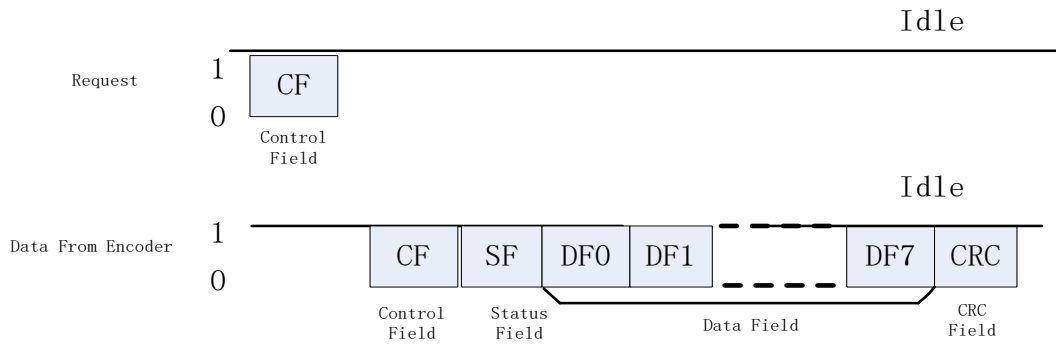

[Note]: The number of DF (Data Frames) varies depending on the CF (Configuration File).

7.3.2 Write E²PROM

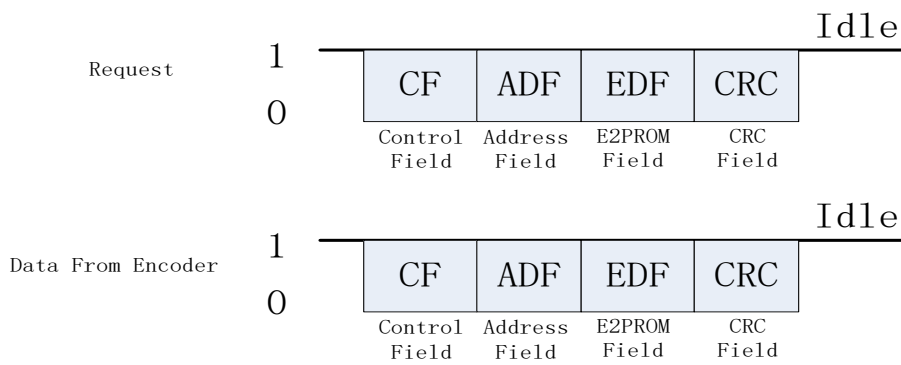

*The request frame and response frame have the same content

7.3.3 Read E²PROM

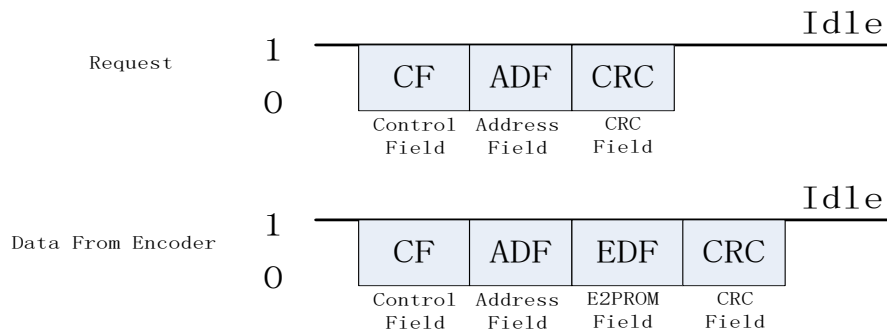

*The request frame and response frame have the same content

7.4 Detailed Description

7.4.1 Control Field (CF)

CF consists of one data word, with categories and contents as shown in the table below:

Items	CF type	Remarks
Read data	ID0(0x02)	Single-turn position information reading (CF+SF+ABS+CRC)
	ID2(0x92)	Encoder ID Information Read (CF+SF+ENID+CRC)

	ID3(0x1A)	Read All Data (CF+SF+ABS+ENID+ABM+ALMC+CRC)
Write E ² PROM	ID6(0x32)	8-bit 'user data' can be written to the specified address. After the instruction format is sent, the encoder will return data within 20 μs. During this process, please avoid communicating with the encoder.
Read E ² PROM	IDD(0xEA)	8-bit 'user data' can be read from the specified address. After the instruction format is sent, the encoder will return data within 20 μs. During this period, please do not communicate with the encoder.
Reset	ID7(0xBA)	The reset command requires sending 10 consecutive instructions with a time interval of no less than 62.5 μs between each, to reset all fault status flags.
	ID8(0xC2)	The reset command requires sending 10 consecutive instructions with a time interval of no less than 62.5 μs between each, to reset and zero the current single-turn position. The position data will remain at the reset value even after power is cycled.

7.4.2 Status Field (SF)

SF is composed of one byte, with each bit defined as shown in the table below:

Bit number	Description	Remarks
Bit0	Rsvd	“0”
Bit1	Rsvd	“0”
Bit2	Rsvd	“0”
Bit3	Rsvd	“0”
Bit4	Counting Error	同 ALMC.Bit2
Bit5	Rsvd	“0”
Bit6	Rsvd	“0”
Bit7	Rsvd	“0”

7.4.3 Data Field (DF0~DF7)

Depending on the CF type, the DF contains a different number of bytes, as detailed in the table below:

CF type	DF0	DF1	DF2	DF3	DF4	DF5	DF6	DF7
ID0 (0x02)	ABS0	ABS1	ABS2					
ID2 (0x92)	ENID							
ID3 (0x1A)	ABS0	ABS1	ABS2	ENID	00	00	00	ALMC
ID7 (0xBA)	ABS0	ABS1	ABS2					
ID8 (0xC2)	ABS0	ABS1	ABS2					

【Note】 :

1. ABS0~ABS2 represent the low, middle, and high bits of the encoder's single-turn position, where the high 7 bits of ABS2 are zero, and the remaining data forms a 17-bit position information.
2. ABM is always "0".
3. ENID is the encoder ID information, with a default value of 0x11.
4. ALMC is the encoder fault status flag, detailed in Section 7.4.4.

7.4.4 Error Description

ALMC faults are detailed in the table below:

Bit	0	1	2	3	4	5	6	7
Name	Over-speed	"0"	Counting Error	"0"	"0"	"0"	"0"	"0"

Descriptions of fault flag bits are as follows:

Name	Function	Action
Over-speed	For 5V power mode, when speed exceeds 7200 RPM	Reset Power
Counting Error	Single-turn information calculation fault	Reset Power

8. Timing Description

8.1 Timing Diagram

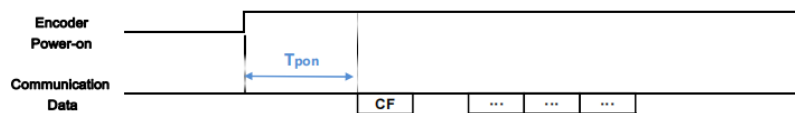

Reagle Power-on Timing Chart

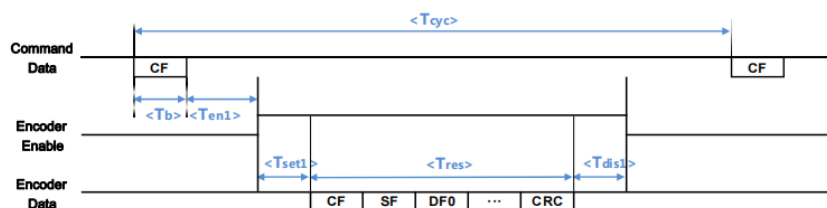

Reagle CF Communication Timing Chart

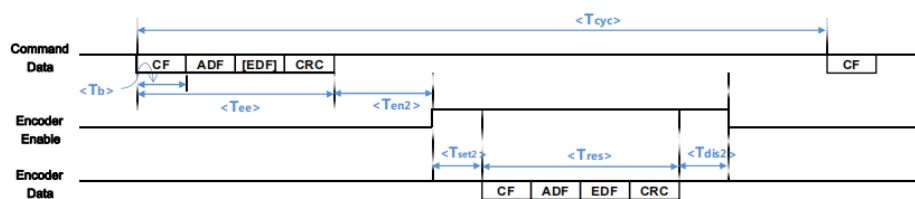

Reagle EEPROM Communication Timing Chart

8.2 Detailed Specifications

Characteristic	Symbol	Minimum	Default	Maximum	Unit	Note
Power-On time	T_{pon}		450	550	ms	
Command cycle period	T_{cyc}	62.5			μs	
Data byte time	T_b		4		μs	
Encoder enable delay time	T_{en1}	1.5		3.5	μs	
	T_{en2}		4.5		μs	
Encoder EEPROM Command time	T_{ee}		12		μs	Read: 3 bytes data
			16		μs	Write: 4 bytes data
Encoder response time	T_{res}		$4 \cdot N$		μs	N bytes data
Encoder data set-up delay time	T_{set1}	0.8		2	μs	
	T_{set2}	1		1.5	μs	
Encoder disable delay time	T_{dis1}	0.6		1.2	μs	
	T_{dis2}		1.3		μs	

SROA Timing Characteristics

Revision History

Date	Version Number	Modification Details or Changes	
		Location	Content
20210831	V1.0	E ² PROM Communication Specifications	Communication Specifications Change/ Addendum Revision Record
20210302	V2.0	Communication Protocol	Detailed Communication Protocol Specification
		Timing	Add Timing Section
20220407	V3.0	Technical Specifications	Modify Allowable Deviation of Output Shaft
			Increase Protection Rating and Operating Environment Description
20220728	V3.1	Structural Parameters	Add Installation Details Description
20221220	V3.2	Structural Parameters	Encoder Height Adjustment

COMMITTED TO SENSING TECHNOLOGY

PROMOTE INDUSTRIAL CIVILIZATION



 www.reagles.cn  sales@reagles.cn  400-636-1110

 Fourth Floor, Block B, Building 9, Intelligence Industry