

# Specification

**Product name:**

**SRMA34-S17Bit-SY-C-5V**

**Main specifications**

Single-turn absolute rotary encoder

**Single-turn resolution:** 17 bit

**Communication protocol:** Reagle-format V1.0

**Baud rate:** 2.5 Mbps

**One to one connection**

**Battery line:** Separate line

**EDLC:** Not mounted

**Maximum rotation speed:** 6,000 rpm

**Comply with RoHS**



# 目录

1. Cautions .....	- 3 -
1.1 Cautions on use .....	- 3 -
1.2 General Precautions .....	- 4 -
2. Basic Specifications .....	- 5 -
2.1 Overview .....	- 5 -
2.2 Features .....	- 5 -
2.3 Classification of Operating States .....	- 6 -
2.4 Serial communication .....	- 6 -
3. Mechanical Specifications .....	- 6 -
3.1 Mechanical Dimensions and Drawings .....	- 7 -
3.2 Recommended Shaft Requirement .....	- 8 -
4. Electrical Specifications .....	- 8 -
4.1 Electrical characteristics .....	- 8 -
4.2 Specifications in Single-turn .....	- 9 -
5. Communication Specifications .....	- 10 -
5.1 Serial Communication Specifications .....	- 10 -
5.2 Frame Format .....	- 10 -
5.3 Detailed description .....	- 12 -
6. Electrical Specifications of EEPROM .....	- 14 -
7. Input/Output Signal .....	- 14 -
8. Environmental Conditions .....	- 14 -
8.1 Operating Environment .....	- 14 -
8.2 Vibration and Shock (Test conditions) .....	- 14 -
9. Mounting Procedure .....	- 15 -
9.1 Installation accessories .....	- 15 -
9.2 Installation sequence .....	- 16 -

## 1. Cautions

---

### 1.1 Cautions on use

This chapter describes important precautions for use to prevent failures and malfunctions of this product.

#### **Precautions for storage/ transportation/ mounting location**

Do not mount or store this product in the following types of locations:

- A location which is exposed to direct sunlight
- A location where the ambient temperature exceeds the temperature condition for storing and mounting or where the relative humidity exceeds the condition for storing and mounting.
- A location subject to extreme changes in temperature and dew condensation. \*1
- A location exposed to corrosive gas\*2 (hydrogen sulfide, sulfurous acid, chlorine, and ammonia, etc.) and flammable gas.
- A location exposed to damp, dust, salinity, or metallic particles.
- A location subject to water, oil, or chemical.
- A location subject to excessive vibration or impact.
- \*1: If the motor or the like encoder mounted on is packed, perform dew condensation prevention such as silica gel for drying, etc.
- \*2: Keep in mind that there are cases where corrosive gas is generated due to evaporation of a component of grease around the encoder.

#### **Precautions for mounting**

- By following the manual “9. Mounting Procedure”, mount encoders.
- Pay enough attention to the installation environment so that oil or foreign objects will not enter the inside of the encoder.
- Be sure to take antistatic measure to the installation environment so that excessive voltage will not be applied to electrical parts.
- Pay great attention to the assembling location because vibration and impact on the encoder may cause malfunctions.
- Pay much attention not to apply strong shock such as a hammer to the encoder.
- Fix the encoder cable not to apply tension or bending force to the cable and the adhesive point of it so.
- Pay much attention to the assembling environment such as the method of casing the encoder and wiring of motor cables because noise to the encoder may cause malfunctions.
- Be sure to use a metallic case, which can be electromagnetically shielded, as an encoder case, and to keep potential stable. Be sure to secure the space between electrical parts in the base plate and the encoder case.
- If electromagnetic field generated by the motor located next to the encoder or generated by welding current is applied to the encoder case, use soft magnetic material (soft iron,

etc.) as the material of the encoder case.

- Do not place the motor power line near the encoder.
- Be sure to ground the FG line of the motor and the FG line of the mechanical device.
- Take countermeasures against surge on the AC power supply component on the supply side with a surge protector, etc., so that surge does not affect the DC power supply line to the encoder.
- After mounting of the encoder, please adequately perform system evaluation in advance.
- Do not conduct voltage resistance tests and insulation resistance test to the encoder.
- Do not use the product that is dropped or accidentally hit by tools.

#### **Precautions for Wiring**

- Be sure to perform correct wiring.
- Perform wiring while the power is turned off.
- Use in specified power supply voltage. Take into consideration the voltage drop of the power supply depending on the length of wiring.
- Do not put the encoder wiring and other power lines through the same duct, and do not use them by bundling in parallel.
- Use twisted pair lines for signal lines and power supply lines of the encoder wiring.
- Use braided shield wires for encoder wiring cables. Braided shield wires must be grounded at both the encoder side and the other side (i.e., the controller side).

#### **Precautions for operation**

- Conduct thorough review and check of the safety design of the device to prevent failures and malfunctions of the encoder before use of the product.
- When an alarm occurs, remove the cause and secure the safety first, and then reset the alarm to restart the operation.
- Do not apply excessive force to the cables.
- Impress neither excess voltage nor the backward voltage that exceeds the absolute maximum rating. There is a possibility that the fear of the destruction of the element or the ignition happens.

### **1.2 General Precautions**

- This product is used being incorporated into a general electronic equipment (e.g., office automation equipment, communication devices, home appliances, amusement apparatus, measuring instrument, general industrial devices). Please note it is not intended for the use which requires extremely high reliability and safety (e.g., transportation equipment, aerospace instrument, nuclear control system, life-support medical equipment).
- We are trying to improve the quality and the reliability, but in general, it is impossible to completely avoid malfunction and failure of semiconductor products are unavoidable. When using this product, please adopt safety precautions to avoid accidents considering the situation which may occur by malfunction, etc. of this product. We do not bear responsibility for damages and adverse effects on lives or property of other people

caused by malfunction, failure, or the life span of this product, or for failure of the equipment, the facility, or the machinery where this product is installed or used, except only the responsibility to consider safety related to this product. This section prescribes exclusionary items only with regard to product liability. Please implement safety design of the system on your responsibility.

- Some of the parts used on our absolute encoder are also provided by a second source to be prepared for discontinuation and for stable supply (e.g., photoreceivers, transceivers). We consider there is no problem based on the confirmation that there is no difference in the function and the quality by adequate evaluation of reliability for the combined adoption. We can trace the part by lot unit based on the serial number of the product, and we sincerely respond with regard to the quality control. We appreciate your understanding. If there is any change in the part or the outside specification, or when we judge that there is any significant effect on the quality, we will submit an application form for the change in the manufacturing condition.
- The product and the technology of the product (including the software) described in this document fall under the restricted freight prescribed in “Foreign Exchange and Foreign Trade Act,” etc. They shall not be exported without authorization from the appropriate government authorities.

## 2. Basic Specifications

---

### 2.1 Overview

- This is a single-turn absolute encoder to output absolute position information within a 17 bit.

Table 2.1 Specification		
Single-Turn resolution	$2^{17}$	(0~131071)
Maximum rotating speed	In normal operation 6,000 rpm	

### 2.2 Features

- Data can be written and read into and from the non-volatile memory installed in an encoder.
- The operating temperature range is  $-10^{\circ}\text{C}$  to  $+105^{\circ}\text{C}$ .
- Signal adjustment by hand is not needed, and the assembly with motor is simplified furthermore.

## 2.3 Classification of Operating States

There are three operational statuses depending on the states of power supply voltages as is in Table 2.2.

Table 2.2	
State	Supply voltage $V_{CC}$ (TYP)
Normal operation	4.75 V ~ 5.25 V
Non operation	Less than 4 V

In the normal operation state, calculation of single-turn data and transmission and reception of data are available.

Transmission and reception of data get available after a maximum of 550 ms or more has passed since the main power is turned on.

### **Non operation state**

In the non-operation state, all operations of the encoder are stopped.

## 2.4 Serial communication

An encoder and controller is connected in one-to-one correspondence. Data can be sent and received based on a half-duplex bidirectional serial communication system that conforms to RS-485. An encoder converts the prescribed data into a serial signal for transmission by sending the prescribed command signal to the encoder.

## 3. Mechanical Specifications

---

The outside dimensions and mechanical specifications of an encoder are described below.

- The position obtained after assembling to a motor is not guaranteed.
- The dimensions and tolerance in a figure are shown in units of millimeters.

### 3.1 Mechanical Dimensions and Drawings

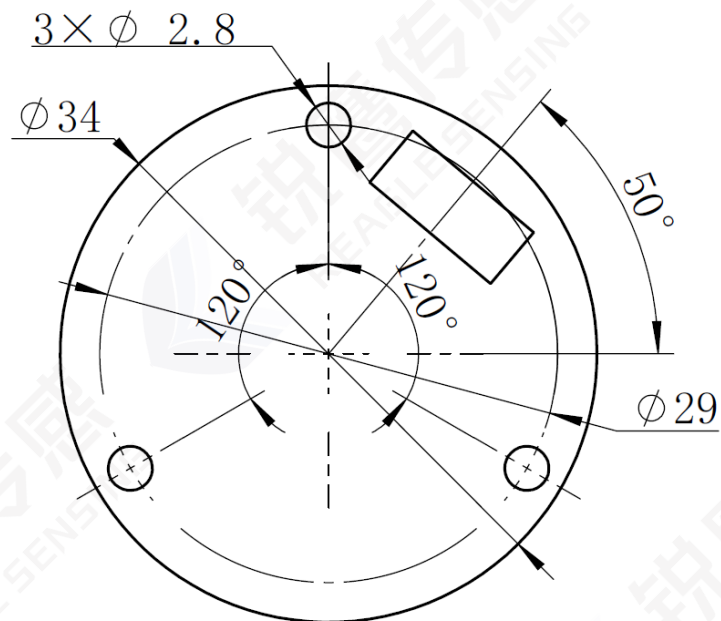
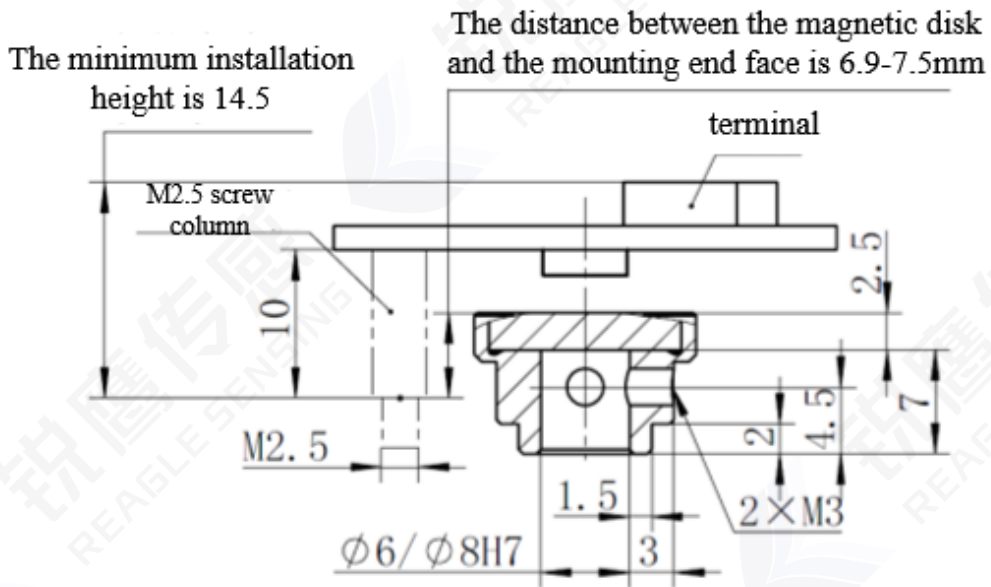

Figure 3.1 SRMA34-S17Bit-SY-C-5V

#### Note

1. We provide m3\*4 fastening screws
2. M3 combination screws are recommended for fixing holes on both sides of the encoder, the length of bolt is determined by the thickness of motor end cover.
3. For the tightening torque, corresponding to the "9.Mounting Procedure".



### 3.2 Recommended Shaft Requirement

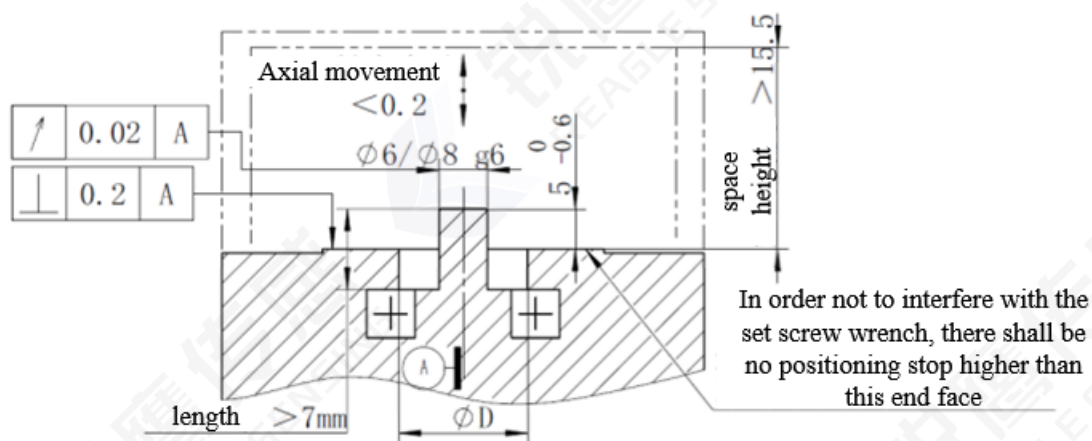

- 1、 The lower end of the encoder shaft will be lower than the mounting end face of the motor, if the diameter of shaft is  $\phi 6$ ,  $\phi D$  must be greater than  $\phi 9.5$ ; if the diameter of shaft is  $\phi 8$ ,  $\phi D$  must be greater than  $\phi 14.5$ .
- 2、 It is recommended to install ferromagnetic materials with a diameter greater than 35mm on the rear cover of the motor.

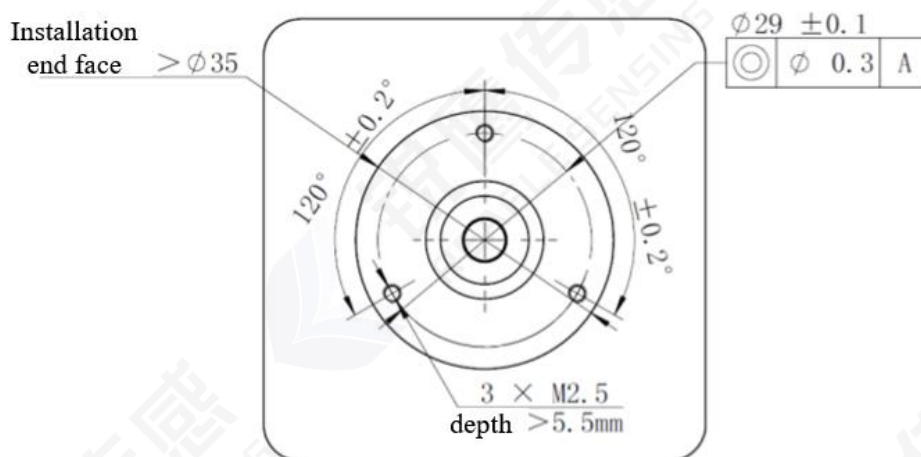

Figure 3.2 motor shaft and end face

## 4. Electrical Specifications

### 4.1 Electrical characteristics

Table 4.1

Items	T=25°C		
	Min.	Typ.	Max.
Main power supply voltage	4.75 V	5V	5.25V
Main power supply Current(Typ)	--	72mA	--
Differential	H	3.5V	--

Level	L	--	--	1.7V
Rise/Fall time		--	--	100ns
Insulation resistance		50MΩ	--	--

## 4.2 Specifications in Single-turn

Table 4.2		
Item	Specification	Remarks
Single-turn resolution	$2^{17}$	0~+131071
Maximum rotating speed (In normal operation)	6,000 rpm	-
Maximum angle acceleration (In normal operation)	$8.0 \times 10^4 \text{ rad/s}^2$	Depending on the mechanical limits
Output code	Pure binary code	-
Direction of increase	CCW	See Figure 4.1.

### Definition of rotation direction

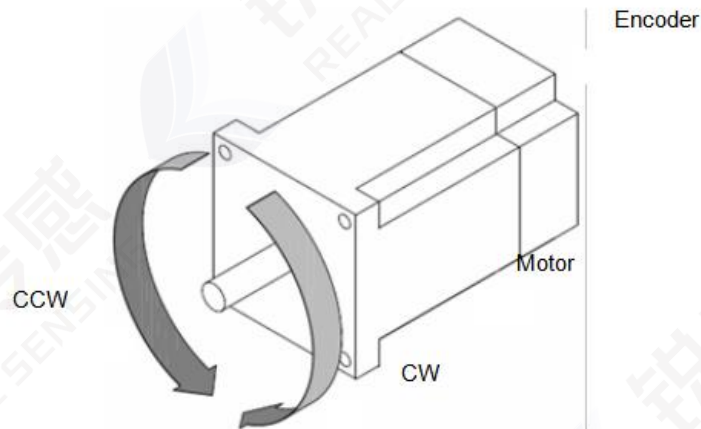

Figure 4.1

## 5. Communication Specifications

### 5.1 Serial Communication Specifications

Table 5.1		
Transmission method	Half-duplex serial communication	Compliance with the EIA standard RS-485
Transmission code	NRZ code	
Synchronous method	Asynchronous communication	
Baud rate	2.5 Mbps	
Communication protocol	Reagle-format V1.0	
Command data		
Number of transfer fields	1 to 4 fields	
Field configuration	10 bits	
Encoder data		
Number of transfer fields	4 to 11 fields	
Field configuration	10 bits	

#### Overview

A one-to-one connection is established between an encoder and a controller, by sending the prescribed command signal to an encoder, the encoder outputs each data item and sets an encoder address as prescribed according to the contents (command code) of a command.

### 5.2 Frame Format

Each data frame is divided into several bytes. The transmission and reception of each byte is realized by one start bit, eight data bits and one stop bit, with the low bit first and the high bit last.

The relation between Data ID code and Data field is shown in Table 5.2.

Table 5.2		
Items	Description	Remarks
CF	Control Field	To identify different commands
SF	Status Field	To acquire status of encoder
DF	Data Field	-
ADF	Address Field	-
EDF	E <sup>2</sup> PROM Field	
CRC	CRC Check	x8+1 (XOR)

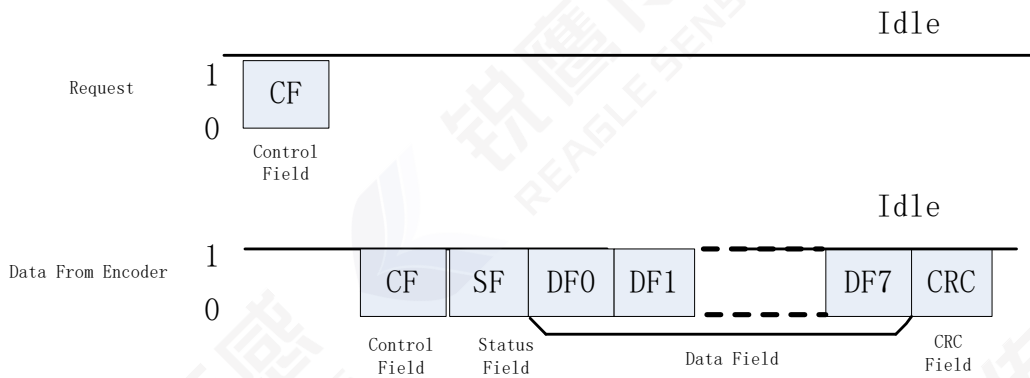
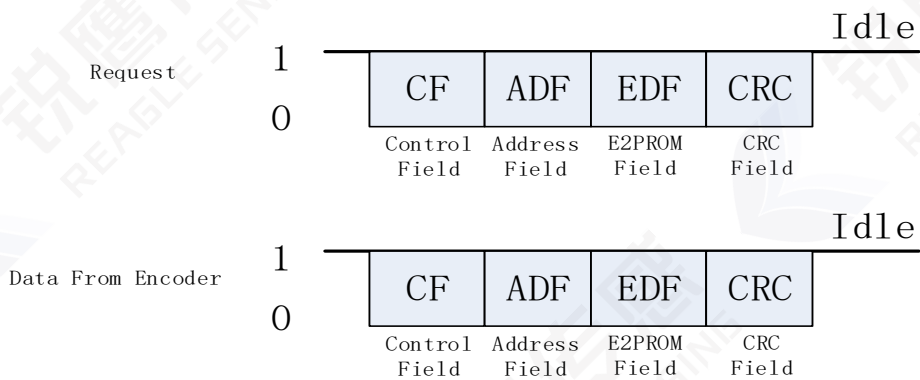
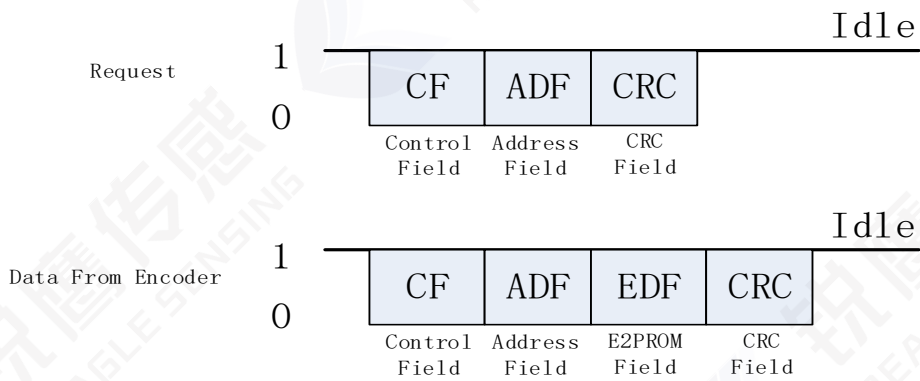

Figure 5.1 Data Access



\* The command and feedback are the same

Figure 5.2 Writing to EEPROM



\* The content of access address is added to the returned data

Figure 5.3 Readout from EEPROM

## 5.3 Detailed description

### 5.3.1 Control Field (CF)

Table 5.3		
Items	CF type	Remarks
Read data	ID0(0x02)	Absolute position access (CF+SF+ABS+CRC)
	ID2(0x92)	ENID access (CF+SF+ID+CRC)
	ID3(0x1A)	Read all information (CF+SF+ABS+ID+ABM+ALMC+CRC)
Write E <sup>2</sup> PROM	ID6(0x32)	“User Data” of 8 bits can be written to the address designated.
Read E <sup>2</sup> PROM	IDD(0xEA)	“User Data” of 8 bits can be readout from the address designated.
Reset	ID7(0xBA)	Transmit 10 times in one sequence with the interval of 62.5us or more at stationary of the shaft. All latched errors are reset at the same time.
	ID8(0xC2)	Transmit 10 times in one sequence with the interval of 62.5us or more at stationary of the shaft. The angle position that is reset once is kept even after the power supply is turned off in spite of existing the external battery.

### 5.3.2 Status Field (SF)

Table 5.4		
Bit number	Description	Remarks
Bit0	Rsvd	“0”
Bit1	Rsvd	“0”
Bit2	Rsvd	“0”
Bit3	Rsvd	“0”
Bit4	Counting Error	Equal to ALMC.Bit2
Bit5	Rsvd	“0”
Bit6	Rsvd	“0”
Bit7	Rsvd	“0”

### 5.3.3 Data Field (DF0~DF7)

CF	DF0	DF1	DF2	DF3	DF4	DF5	DF6	DF7
ID0 (0x02)	ABS0	ABS1	ABS2					
ID2 (0x92)	ENID							
ID3 (0x1A)	ABS0	ABS1	ABS2	ENID	ABM0	ABM1	ABM2	ALMC
ID7 (0xBA)	ABS0	ABS1	ABS2					
ID8 (0xC2)	ABS0	ABS1	ABS2					

**Note**

1. ABS0~ABS2: Absolute data in one revolution. ABS0 is located to lower byte and ABS2 is located to higher byte in the frame of total 24bits. Higher 7 bits of ABS2 are always logic 0.
2. ABM0~ABM2 Multi-turn data. ABM0 is located to lower byte and ABM1 is located to higher byte. AMB2 is 0 fixed.
3. ENID: Encoder ID=0x11(17Bit), can be modified.
4. ALMC: Encoder error, see 5.3.4.

### 5.3.4 Encoder error

Bit	0	1	2	3	4	5	6	7
Name	Over-speed	"0"	Counting Error	"0"	"0"	"0"	"0"	"0"

ALMC:

### 5.3.5 Error description

Name	Function	Action
Over-speed	Rotating speed is more than 7200RPM during Main power mode	Reset Power
Counting Error	Inner Status error	Reset Power

## 6. Electrical Specifications of EEPROM

Items	Address	Description	Remarks
Access address	(0~0x7E)*8 pages	User parameters fields	This address field can be used to store user parameters. Some areas on page 8 are reserved and not recommended for customers
	0x7F	0~7	Within this range
Permissible times for writing	100000times	—	Writing 1 access=1 time

## 7. Input/Output Signal

Color	Definition
Red	5V
Black	GND
Blue	485+
Yellow	485-
Brown	NC(Not connected)
White	NC(Not connected)
Shield	PE

### Note

Cable Size OD: 5.8±0.2mm Core: 19 / 0.08 (AWG28) Insulator: 0.85mm TYP

## 8. Environmental Conditions

### 8.1 Operating Environment

Operating environment conditions are shown in Table 8.1.

Items	Condition
Temperature	In operation
	In non-operation
Humidity	≤90% (40°C /21d, According EN 60068-2-78); No dew condensation.

### 8.2 Vibration and Shock (Test conditions)

The conditions of vibration test and shock test for encoder is shown in Table 8.2.

It is confirmed that the encoders are not broken after tested in each condition.

Table 8.2		
Color	Definition	
Vibration	Direction	X、Y、Z direction
	Testing time	2 h (each direction)
	Frequency	55 Hz to 2000 Hz (Acceleration-98 m/s <sup>2</sup> ) 10 Hz to 55 Hz (Maintain amplitude of 1.5mm)
Shock	Acceleration	980 m/s <sup>2</sup> (11 ms)
	Direction	X、Y、Z direction
	Number of tests	3 times (each direction)

## 9. Mounting Procedure

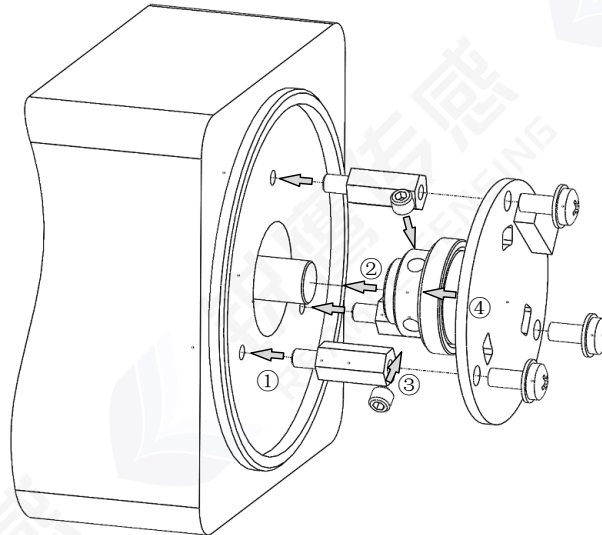

### 9.1 Installation accessories

- ① metric opposite side 1.5mm hexagonal torque wrench
- ② Metric opposite side 4.0mm hexagon socket torque wrench
- ③ Cross torque screwdriver



## 9.2 Installation sequence

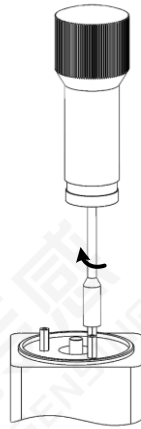

**One.** Put three m2.5 × 10 Dip the external thread of the stud with thread sealant, screw it into the rear end cover of the motor with the corresponding hexagonal socket torque wrench, and the locking torque is 4 ~ 5 kgf·cm.

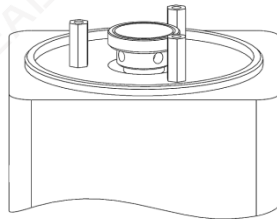

**Two.** To Thread the encoder shaft assembly into the motor shaft to make the assembly fit with the end face of the shaft.

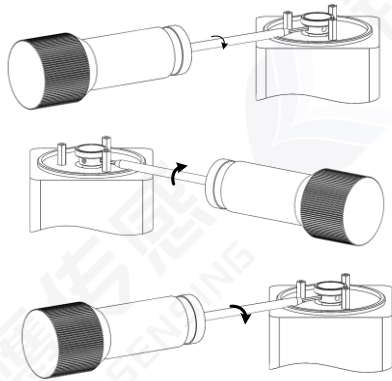

**Three.** Dip the head of M3 set screw with thread sealant, screw the first set screw into the encoder shaft with the corresponding hexagonal torque wrench, and lock it gently to make it contact the motor shaft; Dip the head of the second fastening screw with thread glue, screw it into the encoder shaft and lock it with 7kgf·cm torque; Then lock the first screw with 7kgf·cm torque.

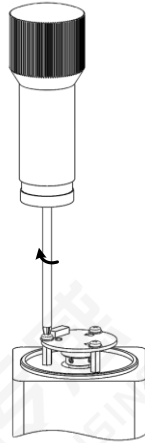

**Four.** Align the holes on the encoder circuit board with the threaded holes of the corresponding studs, and connect the three m2 5. Screw in the combination screws with thread sealant respectively, and then lock the screws in turn with 3 ~ 4 kgf · cm torque.

(Note: Do not lock one screw completely before locking the other two during installation)

*Service hotline: 400-636-1110*

**COMMITTED TO SENSING TECHNOLOGY**

**PROMOTE INDUSTRIAL CIVILIZATION**



[www.reagles.cn](http://www.reagles.cn)



[sales@reagles.cn](mailto:sales@reagles.cn)



0573-89891110



Fourth Floor, Block B, Building 9, Intelligence Industry