

# Incremental optical Rotary Encoder SROI35-5000P4-P6SY-C-5V SPECIFICATION

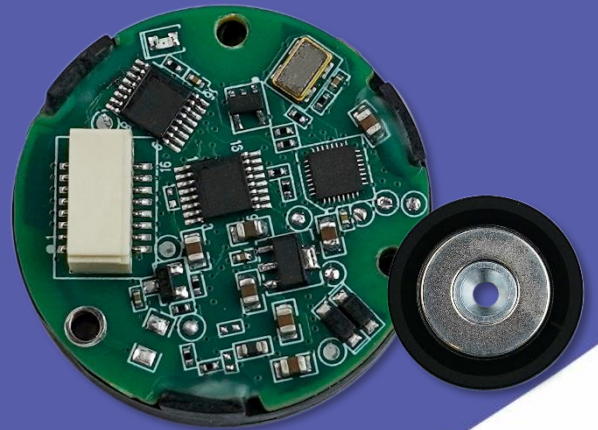

# Contents

1. Summary Info.....	2
2. Naming convention .....	2
3. Technical Specifications.....	2
4. Electrical Parameters .....	3
5. Output Phase Difference.....	4
6. Cable Definition.....	4
7. Mechanical Specifications.....	5
8. Mounting Procedure.....	7
8.1 Installation Diagram.....	7
8.2 Installation Accessories .....	7
8.3 Installation Sequence.....	7

## 1. Summary Info

Reagle Sensing SROI35 Incremental Optical Encoder product models are as follows:

Model Series	Features	Installation Features
SROI35-5000P4-P6SY-C-5V	Outer Diameter:35mm; Resolution:5000 C/T; Pole Pairs:4;	Straight ShaftΦ6

## 2. Naming convention

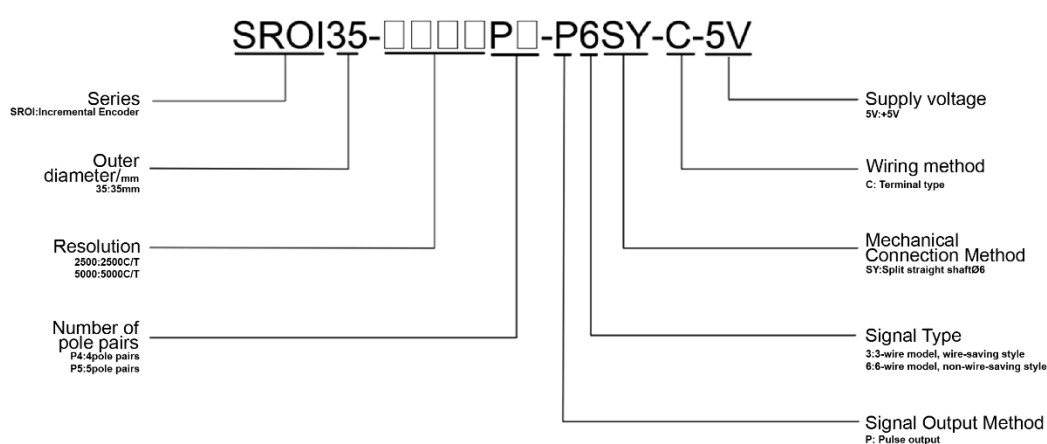

## 3. Technical Specifications

Model	SROI35-5000P4-P6SY-C-5V
Resolution	5000 Lines
Communication frequency	≤500KHz
Input shaft allowable deviation	Axial play: <math>\leq \pm 0.15\text{mm}</math> Radial play: <math>\leq 0.01\text{mm}</math> Perpendicularity of Stator Mounting Surface to Shaft Center 0.05mm Perpendicularity of Shaft End Face to Axial Direction 0.01mm
Main shaft speed	≤6000rpm
Shaft Diameter	straight shaft $\Phi 6\text{mm}$
Moment of inertia	0.15kg · mm <sup>2</sup>

Weight	≈0.016 kg (Without Cable)
Rotor angular acceleration	≤10000rad/s <sup>2</sup>
Vibration	Between 10 and 55Hz, maintain amplitude of 1.5mm. Between 55 and 2000Hz, acceleration is 98m/s <sup>2</sup> . 2 hours per axis for XYZ, totaling 6 hours
Mechanical shock	Shock acceleration of 980m/s <sup>2</sup> , 11 milliseconds. 3 impacts per direction, totaling 18 impacts
Operating Temperature/ Storage Temperature	-20°C~+85°C / -25°C~+85°C
Relative Humidity	≤90% (40°C/21 days, based on EN 60068-2-78); No condensation
Enclosure Protection Rating	/
Electromagnetic Compatibility	Complies with IEC 61800-3 standard requirements.
Output Format	Line Driver
ESD Resistance	4kV Contact Discharge
Magnetic Interference Resistance	Common Mode Magnetic Field Suppression

#### 4. Electrical Parameters

Items	T=25°C		
	Min.	Typ.	Max.
Main power supply voltage	4.75V	5V	5.25V
Main Power Supply Current Consumption (No Load)	--	80mA	--
Differential Level	High	2.4V	--
	Low	--	0.5V
Edge Change Time	--	--	100ns
Insulation resistance	10MΩ	--	--
Insulation Voltage Withstand	AC500V 1min		

## 5. Output Phase Difference

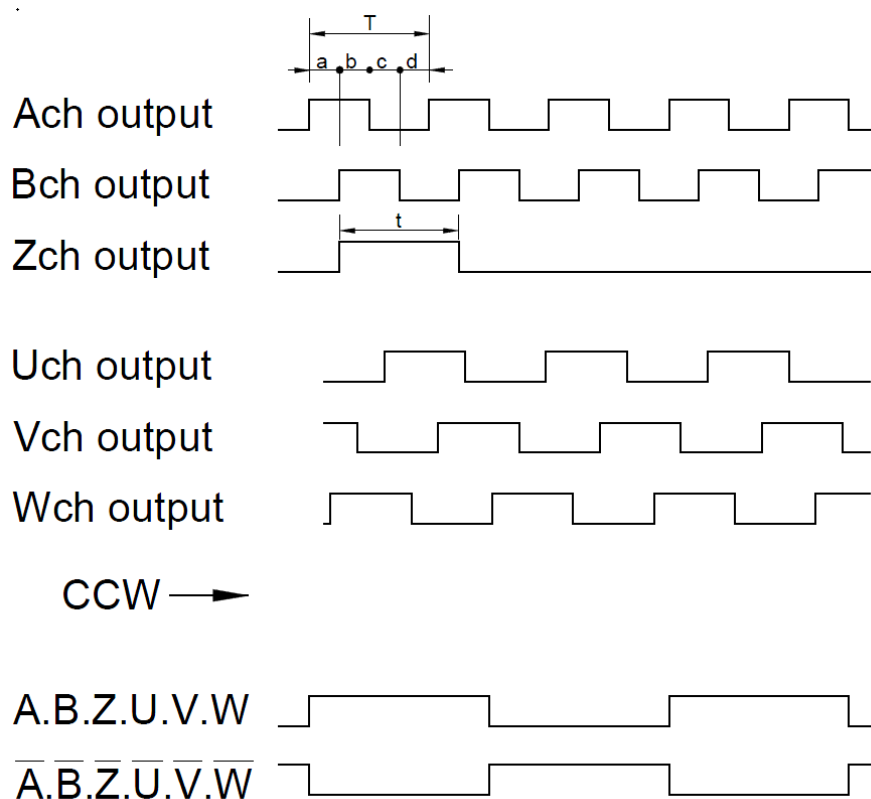

$$T = \frac{360^\circ}{5000}$$

$$a.b.c.d = \frac{T}{4} \pm \frac{T}{8}$$

$$t = T \pm \frac{T}{2}$$

## 6. Cable Definition

Cable color	Definition
Shielding	PE
White	Z-
White-Black	Z+
Blue-Black	B-
Blue	B+

Green-Black	A-
Green	A+
Yellow-Black	U-
Yellow	U+
Brown-Black	V-
Brown	V+
Gray-Black	W-
Gray	W+
Black	GND
Red	+5V

## 7. Mechanical Specifications

### ◇ Product Structure Dimension Diagram

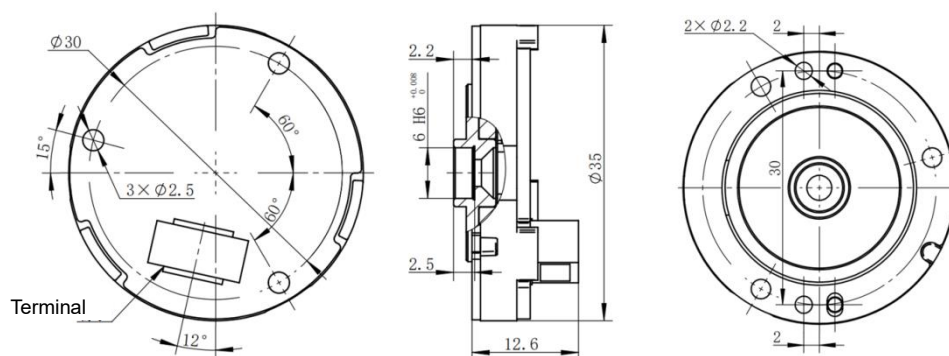

◇ Recommended Installation Dimensions

- Straight shaft Installation

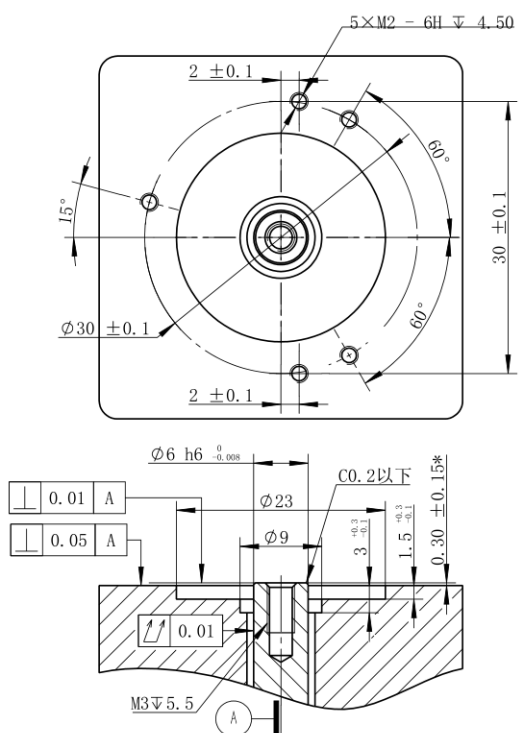

\* When the axial size tolerance is not met, shims must be used for adjustment. The axial play of the motor shaft must be within  $\pm 0.15$ mm.

- Step Shaft Installation

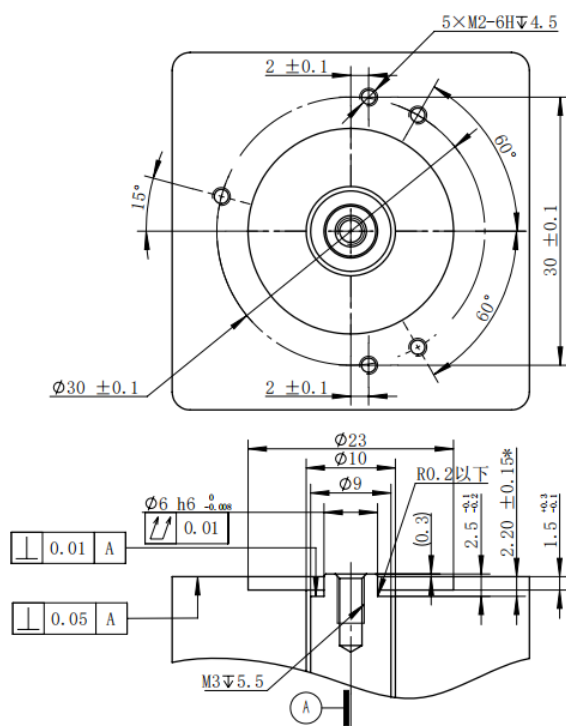

\* When the axial size tolerance is not met, shims must be used for adjustment. The axial play of the motor shaft must be within  $\pm 0.15$ mm.

## 8. Mounting Procedure

---

### 8.1 Installation Diagram

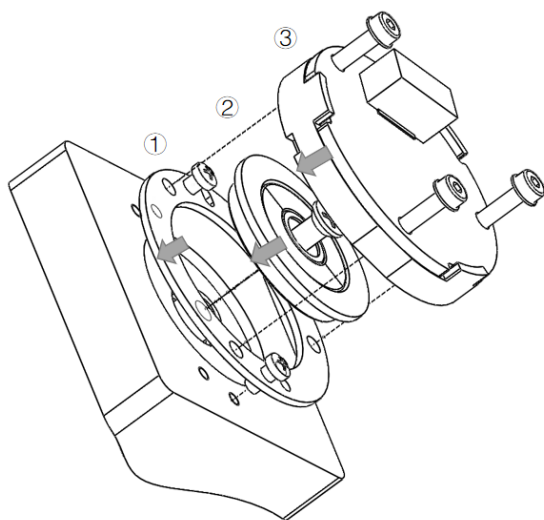

### 8.2 Installation Accessories

- Cross screwdriver
- Metric opposite side 1.5mm hexagonal torque wrench

### 8.3 Installation Sequence

1) Install the baseplate: Mount the baseplate onto the motor, ensuring that the 5 mounting holes of the motor end and the baseplate are aligned; Embed the positioning tool into the outer diameter of the motor shaft and the inner diameter of the baseplate, ensuring that the encoder baseplate mounting surface is not suspended; Apply thread-locking adhesive to the bottom of the threads of two M2×4 cross recessed pan head screws, and tighten and secure with a recommended torque of 0.3Nm (2 locations). Remove the positioning tool.

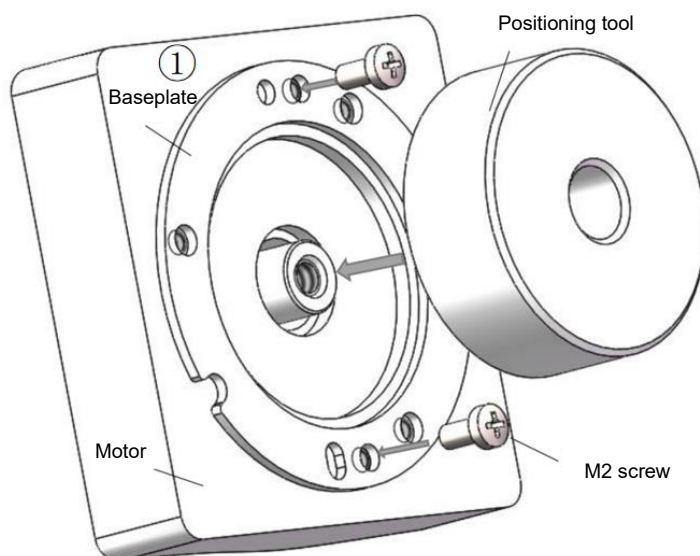



2) Install the encoder disk assembly: Clean the motor shaft with alcohol or similar solvent; Insert the encoder disk assembly into the motor shaft; Lock the motor shaft and, while keeping the motor shaft fixed, apply thread-locking adhesive to the front end of the M3×6 stainless steel cross-recessed countersunk head screws, and secure with a recommended tightening torque of 0.6Nm.

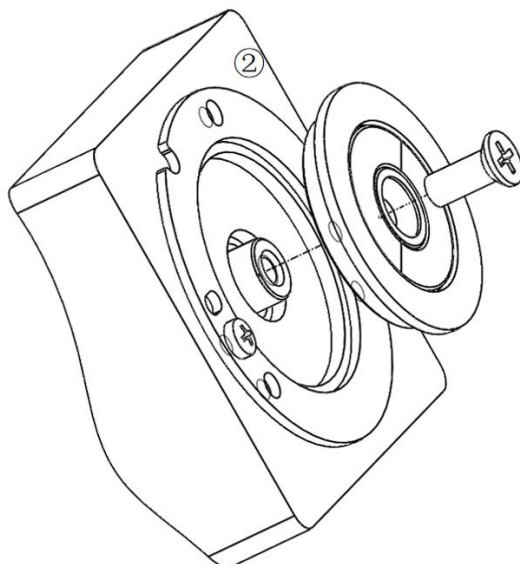

3) Install the main body: From the upper end of the circuit board, align the positioning notch with the baseplate, and match the two positioning protrusions on the main body with the positioning holes on the baseplate. Apply thread-locking adhesive to the threaded ends of the three M2×10 hex socket head cap screws, and install them onto the motor in combination with small washers, tightening and securing with a recommended torque of 0.3Nm (at three locations).

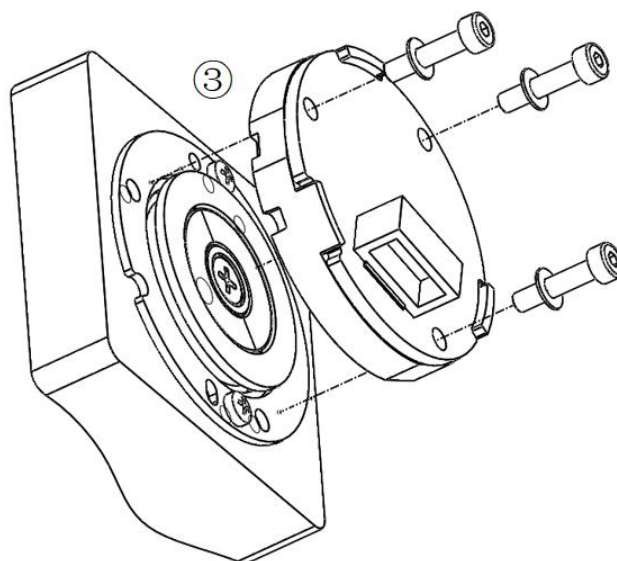

Precautions:

1. This encoder has a split structure, with the encoder shaft (inside the code disk assembly)

separate from the main body structure. The encoder shaft must be exposed to the air when installed on the motor shaft. Please assemble in a clean, dust-free environment.

2. Before installation, degrease and clean the motor shaft to avoid oil and dirt affecting the tightening of the encoder shaft and contaminating the code disk.
3. Please avoid touching the code disk directly with your hands (use specialized tools for handling), as fingerprints, oil, dust, and other contaminants can cause signal abnormalities.
4. After installation, check the cleanliness of the reflective code disk surface. If contaminated, gently wipe with a dust-free cloth dipped in alcohol. Be cautious not to apply excessive force or use other hard materials for cleaning, as this may damage the code disk.

### Revision History

Date	Version Number	Modification Details or Changes	
		Location	Content
20230510	V1.0	/	New Version
20240219	V1.1	Electrical Parameters	"Main power supply current consumption (typical)" to "Main power supply current consumption (no load)"

COMMITTED TO SENSING TECHNOLOGY

PROMOTE INDUSTRIAL CIVILIZATION



 [www.reagles.cn](http://www.reagles.cn)  [sales@reagles.cn](mailto:sales@reagles.cn)  400-636-1110

 Fourth Floor, Block B, Building 9, Intelligence Industry